

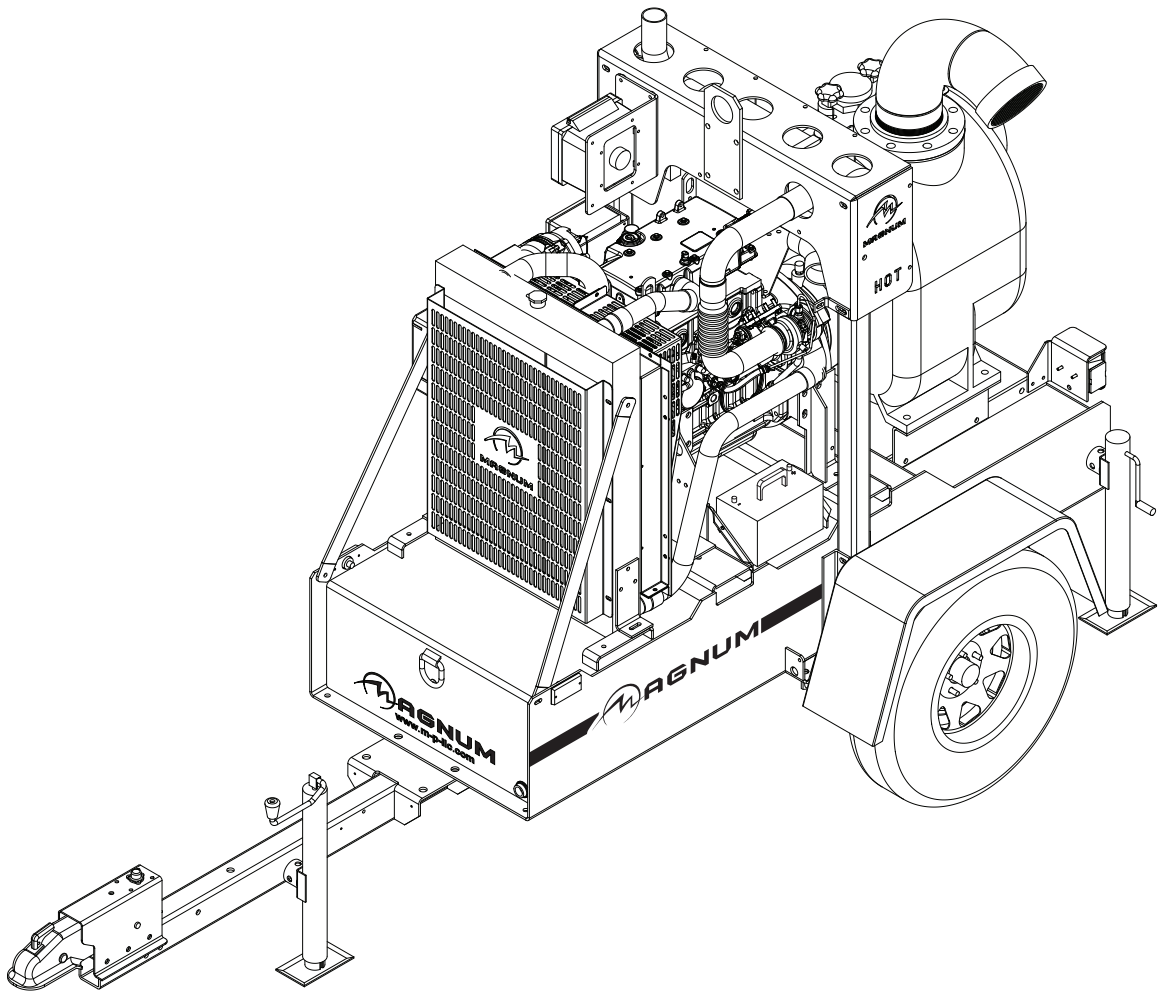

SELF-PRIME DIESEL TRASH PUMP MTP6000S3



PARTS MANUAL

INTRODUCTION

Before servicing this machine, make sure the engine start switch is turned to off "O", the emergency stop switch is closed (pushed in), and the negative (-) terminal on battery is disconnected. Attach a "DO NOT START" sign to the control panel. This will notify everyone that the unit is being serviced and will reduce the chance of someone inadvertently trying to start the unit.

▲ WARNING

Before operating or servicing this equipment, read and understand the Magnum Operating Manual which was included with the unit when shipped from the factory. Failure to do so increases the risk of injury to yourself or others.

MAGNUM POWER PRODUCTS LLC

215 Power Drive • Berlin, WI 54923

U.S.A.

Phone: 920-361-4442

FAX: 920-361-4416

Toll Free: 1-800-926-9768

www.m-p-llc.com

For technical or parts QUESTIONS, please contact the Magnum Power Products Customer Support or Technical Support team at 920-361-4442 or toll free at 1-800-926-9768. Please have your serial number available.

To ORDER SERVICE PARTS, please contact the dealer from which you purchased the unit, or call Magnum Power Products to locate a dealer in your area.

Engine Make: _____

Engine Serial Number: _____

Engine Model Number: _____

Pump Make: _____

Pump Model Number: _____

Pump Serial Number: _____

Unit Model Number: _____

Unit Serial Number: _____

▲ WARNING

CALIFORNIA PROPOSITION 65 WARNING:

Diesel engine exhaust and some of its constituents are known to the state of California to cause cancer, birth defects and other reproductive harm.

TABLE OF CONTENTS

	Page
INTRODUCTION	2
TABLE OF CONTENTS	3
UNIT DECALS	4
UNIT DECALS	5
FUEL TANK ASSEMBLY	6
SKID ASSEMBLY	8
AIR FILTER ASSEMBLY	10
EXHAUST SYSTEM ASSEMBLY	11
ENGINE ASSEMBLY	12
COOLING SYSTEM ASSEMBLY	14
CONTROL BOX ASSEMBLY	16
WET PRIME PUMP ASSEMBLY	18
TRAILER ASSEMBLY	20
TRAILER BRAKE LINES	22
NOTES	23

UNIT DECALS

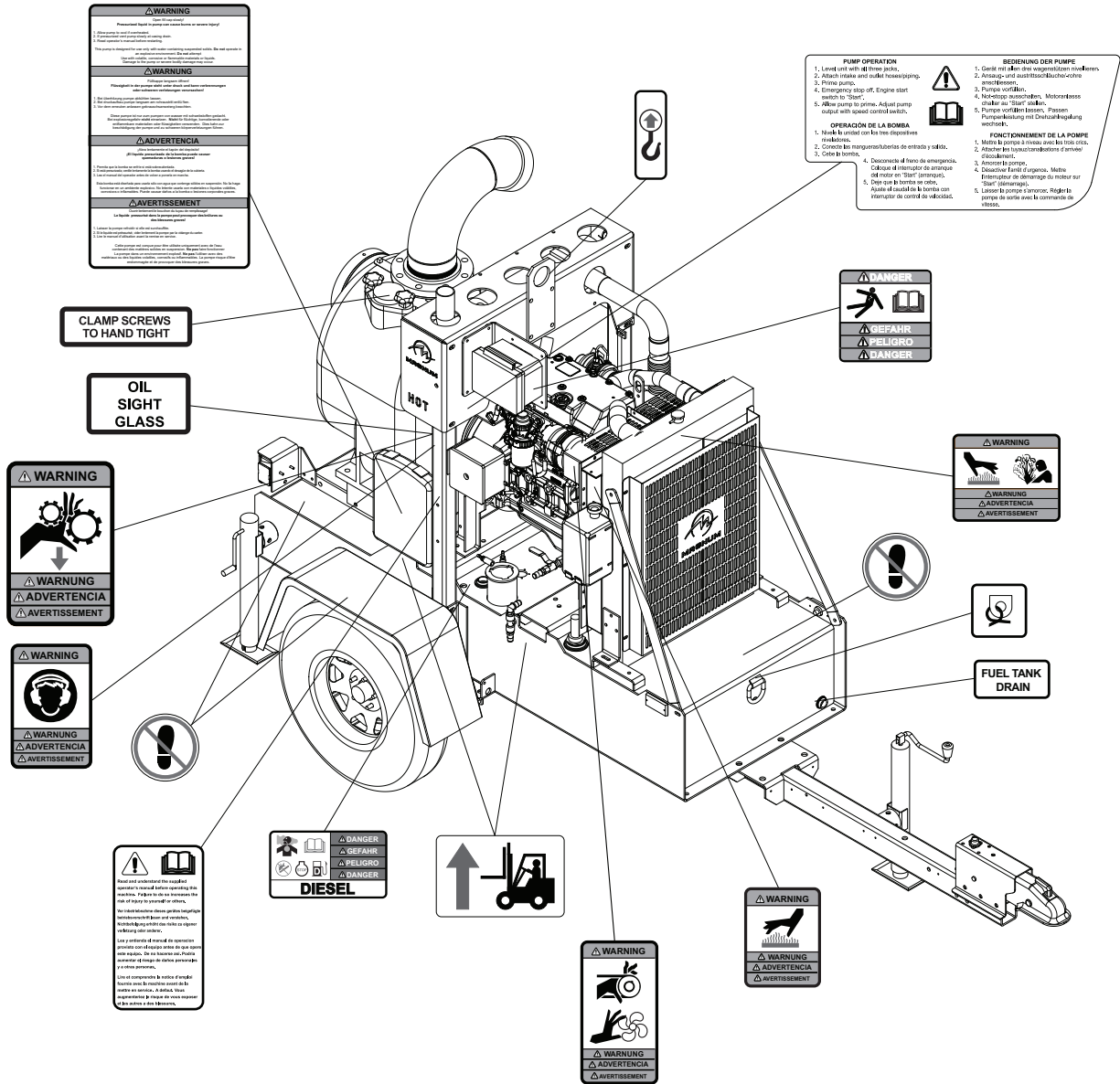

Magnum logo w/ red stripe
Part Number 11174



Magnum logo w/ web
Part Number 11275

Note: All safety and operating decals shown above are located on decal sheet 49531, unless otherwise noted.

FUEL TANK ASSEMBLY

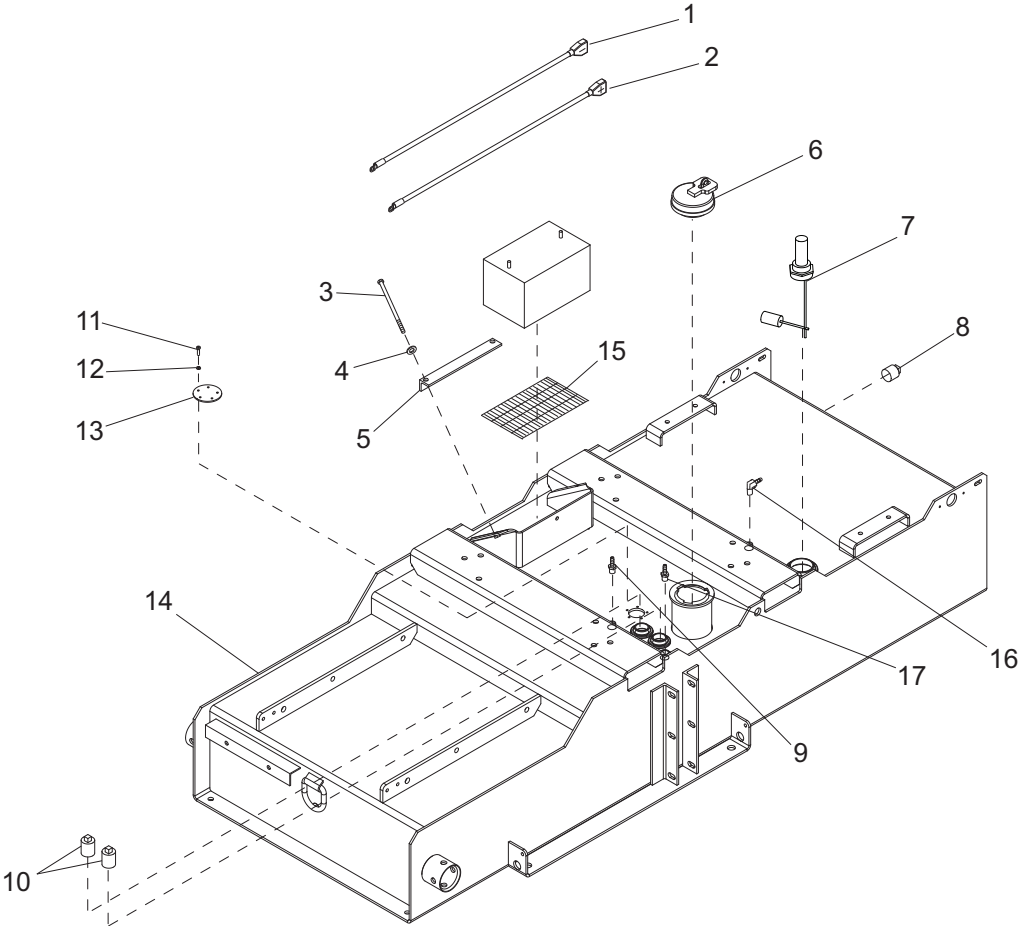

ITEM	PART NO.	QTY	DESCRIPTION	NOTES
1	65686	1	Cable, battery - black	
2	65687	1	Cable, battery - red	
3	60845	2	Screw, .312-18x7.000 hx	
4	60119	2	Washer, flat .312	
5	41055B	1	Bracket, battery tie-down	
6	23707	1	Cap, fuel fill - 3.50	
7	21129	1	Gauge, fuel - mechanical 11" GE(mid)	
8	60498	1	Plug, 1.00 NPT square drive	
9	15142	2	Fitting, .250NPT x .312 barb	
10	60988	2	Plug, 1.00 NPT square drive	
11	60156	5	Screw, M5-0.80 X 16 pan phil	
12	60043	5	Washer, m5 split lock	
13	49762B	1	Cover, fuel sender cutout	
14	41278B	1	Weldment, fuel tank/chassis	
15	41185	1	Battery pad - black pillow	
16	15693	1	Fitting, 90° elbow	
17	23816	1	Fitting, strt - .500 mnpt x .375 barb, brs	

SKID ASSEMBLY

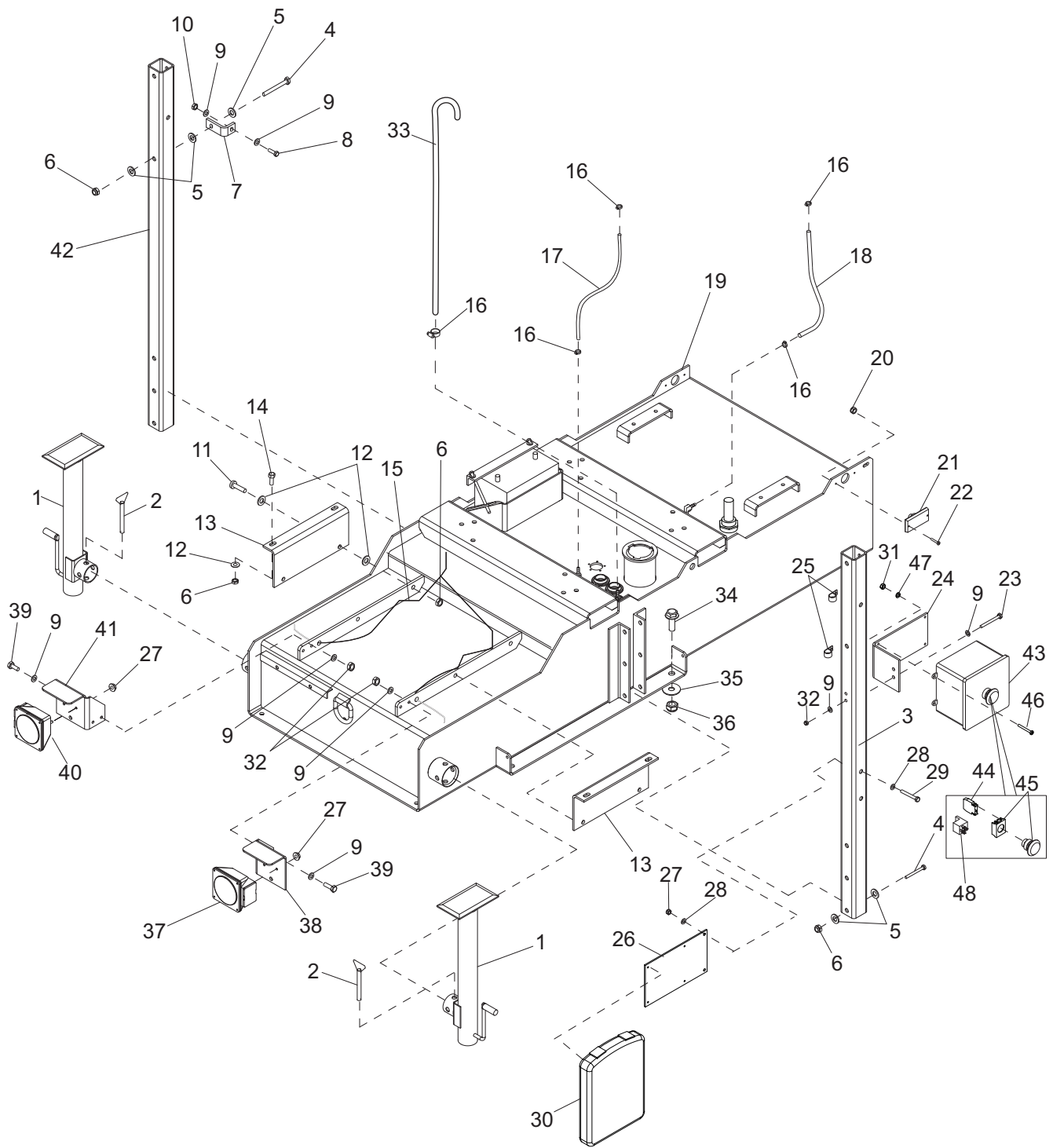

ITEM	PART NO.	QTY	DESCRIPTION	NOTES
1	41133	2	Jack, side wind-tube mount	
2	23256	2	Pin, jack - tube mounted	
3	41108B	1	Tube, lift support	
4	50215	6	Screw, std hex	
5	60416	25	Washer, flat .500 USS	
6	60307	16	Nut, .500-13 hx nylock	
7	41145B	1	Bracket, heat shield	
8	60205	1	Screw, std hex	
9	60119	12	Washer, flat .312	
10	60358	1	Nut, hx nylock	
11	60388	4	Screw, std hex	
12	60309	12	Washer, flat .500	
13	41109B	2	Angle, pump mounting	
14	60328	4	Screw, std hex	
15	41123	1	Harness, trailer Light	
16	60777	5	Clamp, hose crimp style	
17	50018	2.5 ft	Hose, fuel - .312 ID 50 psi	
18	50018	3.0 ft	Hose, fuel - .312 ID 50 psi	
19	41278B	1	Weldment, fuel tank/chassis	
20	60270	4	Nut, 8-32 hx hd nylock	
21	65407	2	Light, clearance - amber	
22	60406	4	Screw, 8-32X1.000 pan phil	
23	60860	2	Screw, std hex	
24	49554B	1	Bracket, E-stop box	
25	15627	3	Clamp, tubing - heavy duty	
26	49556B	1	Bracket, manual box	
27	60144	8	Nut, .250-20 nylock	
28	60243	4	Washer, flat .250 USS	
29	60800	2	Screw, std hex	
30	24540	1	Holder, manual	
31	60318	4	Nut, 8-32 hex G5	
32	60303	6	Nut, .312-18 hx nylock	
33	50343	3.16 ft	Hose, fuel - clear vinyl	
34	61078	4	Screw, flg hex G8 ZB	
35	60180	4	Washer, .625 flat	
36	60240	4	Nut, .625-11 nylock	
37	65448	1	Light, stop/turn/tail - rh	
38	41102B	1	Bracket, tail light -rh	
39	60028	4	Screw, std hex	
40	65449	1	Light, stop/turn/tail -lh	
41	41101B	1	Bracket, tail light -lh	
42	41301B	1	Tube, lift support	
43	49555	1	Box, E-stop Assembly	
44	65584	1	Block, E-stop contactor NO/NO	
45	65470	1	Switch, E-stop operator	
46	60244	4	Screw, 8-32 x .750 pan phil	
47	60252	4	Washer, #10 split lock	
48	66455	1	Relay, 12V 70A NC/80A NO w/diode	

AIR FILTER ASSEMBLY

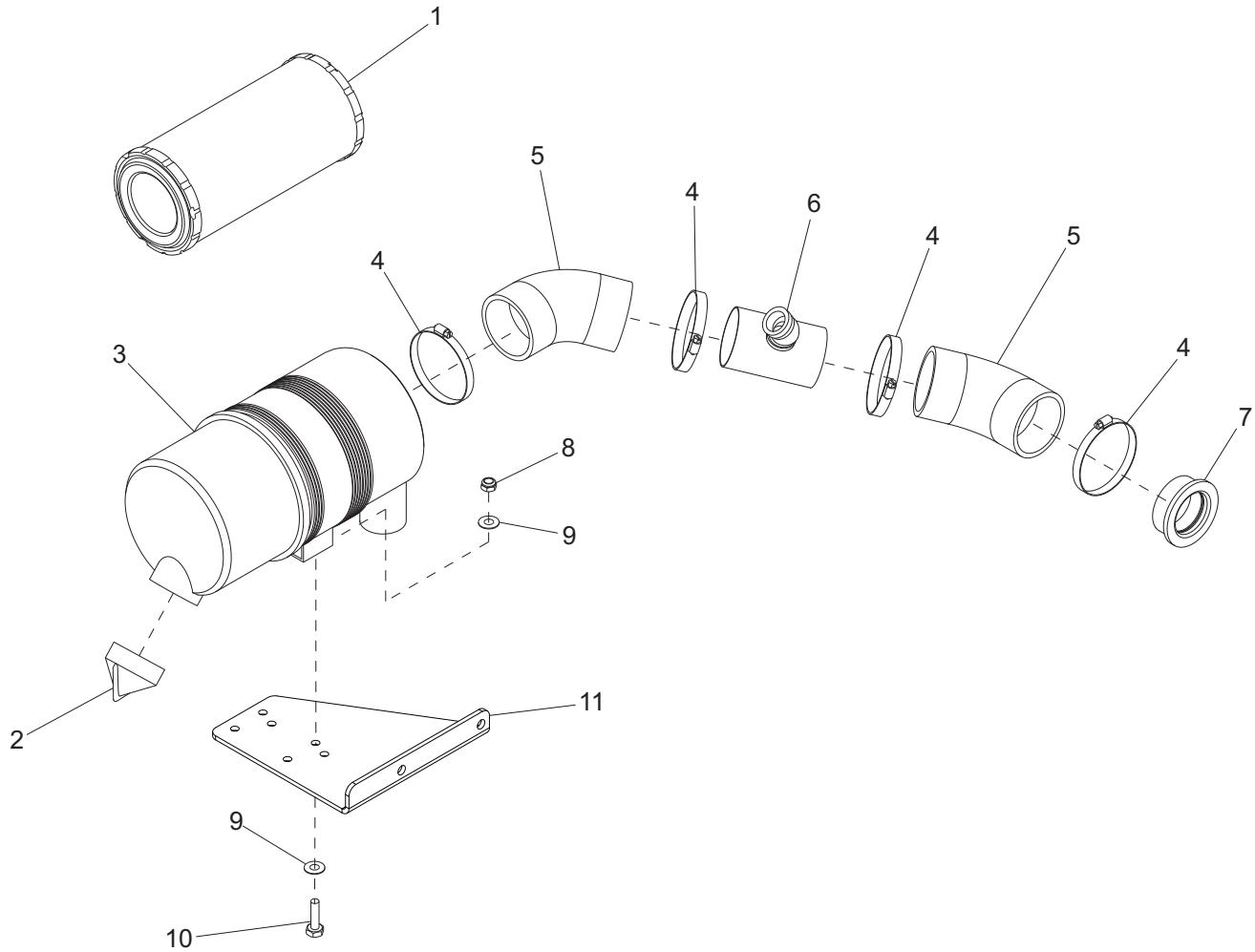

ITEM	PART NO.	QTY	DESCRIPTION	NOTES
1	22874	1	Element, air filter	
2	19277	1	Cap, dust ejector	
3	22967	1	Filter, air	
4	18663	4	Clamp, hose - (3.31-4.25)	
5	41050	2	Elbow, 45 molded rubber	
6	41565B	1	Weldment, air intake tube	
7	22872	1	Insert, air hose reducer	
8	60303	2	Nut, .312-18 hx nylock	
9	60119	4	Washer, flat .312	
10	60028	2	Screw, hx hd	
11	40995B	1	Bracket, air filter	

EXHAUST SYSTEM ASSEMBLY

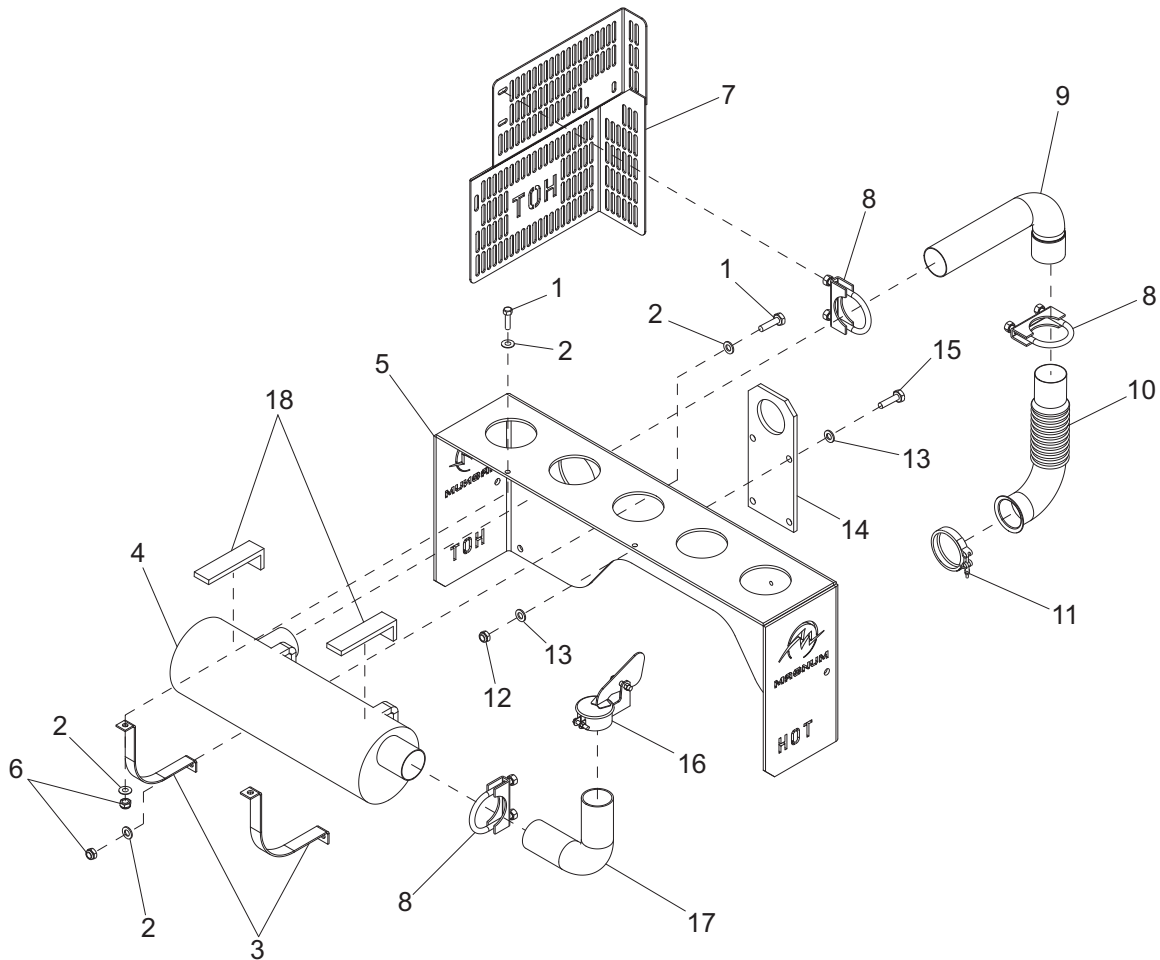

ITEM	PART NO.	QTY	DESCRIPTION	NOTES
1	60352	4	Screw, hx hd	
2	60386	8	Washer, flat .375	
3	41082B	2	Bracket, muffler	
4	22670	1	Muffler, residential	
5	41068R	1	Bracket, lift support	
6	60358	4	Nut, .375-16 hx nylock	
7	41023R	1	Plate, heat shield	
8	61028	3	Clamp, muffler - 2.50	With hardware
9	41117B	1	Pipe, exhaust - upper	
10	41148B	1	Pipe, exhaust - lower	
11	22712	1	Clamp, 2.75" v-band	
12	60307	4	Nut, .500-13 hx nylock	
13	60309	8	Washer, flat .500 SAE	
14	41080B	1	Bracket, lift eye	
15	60484	4	Screw, hx hd	
16	25647B	1	Cap, rain 2.50	
17	41132B	1	Pipe, exhaust - 90°	
18	41083B	2	Spacer, muffler	

ENGINE ASSEMBLY

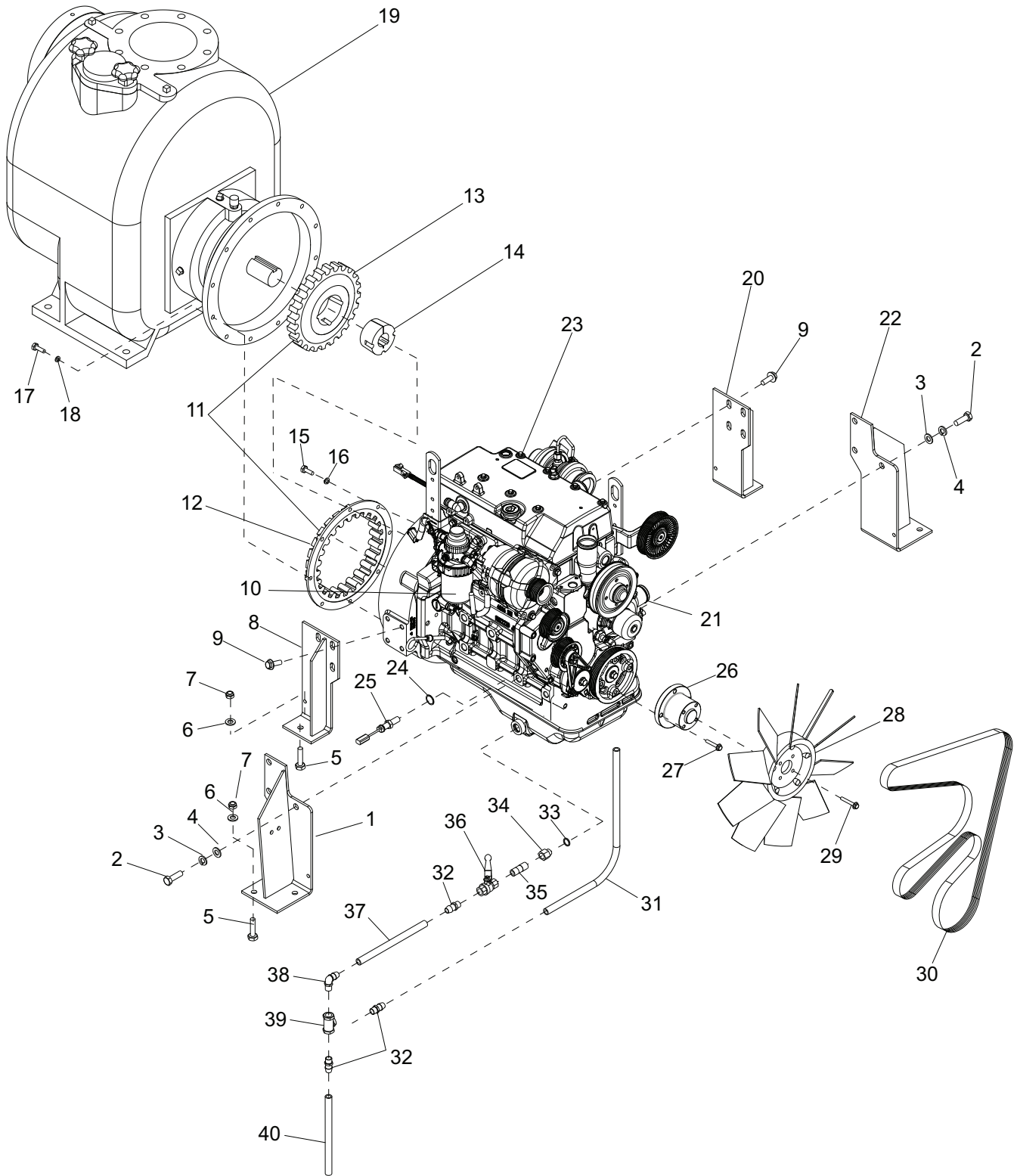

ITEM	PART NO.	QTY	DESCRIPTION	NOTES
1	41112B	1	Weldment, engine mnt - rh	
2	60489	6	Screw, M16x40 hx hd	
3	60194	6	Washer, split lock M16	
4	60126	6	Washer, flat M16	
5	60388	6	Screw, .500 - 13x1.500 hx	
6	60309	6	Washer, flat .500	
7	60307	6	Nut, .500-13 hx nylock	
8	41071B	1	Weldment, eng mnt - rr rh	
9	60065	8	Screw, M12x40 hx ser flg	
10	29488	1	Filter, fuel - 4024HF	
11	41193	1	Coupling flywhl rng/rbbr drvr	Set (items 12 & 13)
12	41191	1	Coupling flywheel ring	
13	41192	1	Coupling rubber driver	
14	41194	1	Coupling hub	
15	60205	8	Screw, .375-16x1.000 hx	
16	60206	8	Washer, split lock .375	
17	60215	12	Screw, M10x1.5x35 hx	
18	60026	12	Washer, split lock M10	
19	49192B	1	Pump, trash - 6" wet prime ES6	
20	41072B	1	Weldment, eng mnt - lh rr	
21	29487	1	Filter, oil - 4024/5030	
22	41113B	1	Weldment, engine mnt - lh	
23	29776	1	Engine, Deere 4024HF285	
24	41205	1	O-ring - J.D. tach sensor	
25	41204	1	Sensor, tach - J.D.	
26	41134	1	Spacer, fan	
27	60859	4	Screw, soc hd	
28	41121	1	Fan, pusher - 18.00 CW	
29	61204	4	Screw, hx ser flg	
30	24845	1	Belt, fan - 35FH/4024 pump	
31	50332	3.09 ft	Hose, fuel - .750 ID 175 psi	
32	41167	3	Fitting, barb strt blk nylon	
33	19467	1	Seal, M22	
34	19307	1	Fitting, brass	
35	60438	1	Nipple, pipe	
36	60985	1	Valve, ball padlocking	
37	50332	.625 ft	Hose, fuel - .750 ID 175 psi	
38	41168	1	Fitting, barb 90° blk nylon	
39	60986	1	Fitting, tee polyprop	
40	50332	1.17 ft	Hose, fuel - .750 ID 175 psi	

COOLING SYSTEM ASSEMBLY

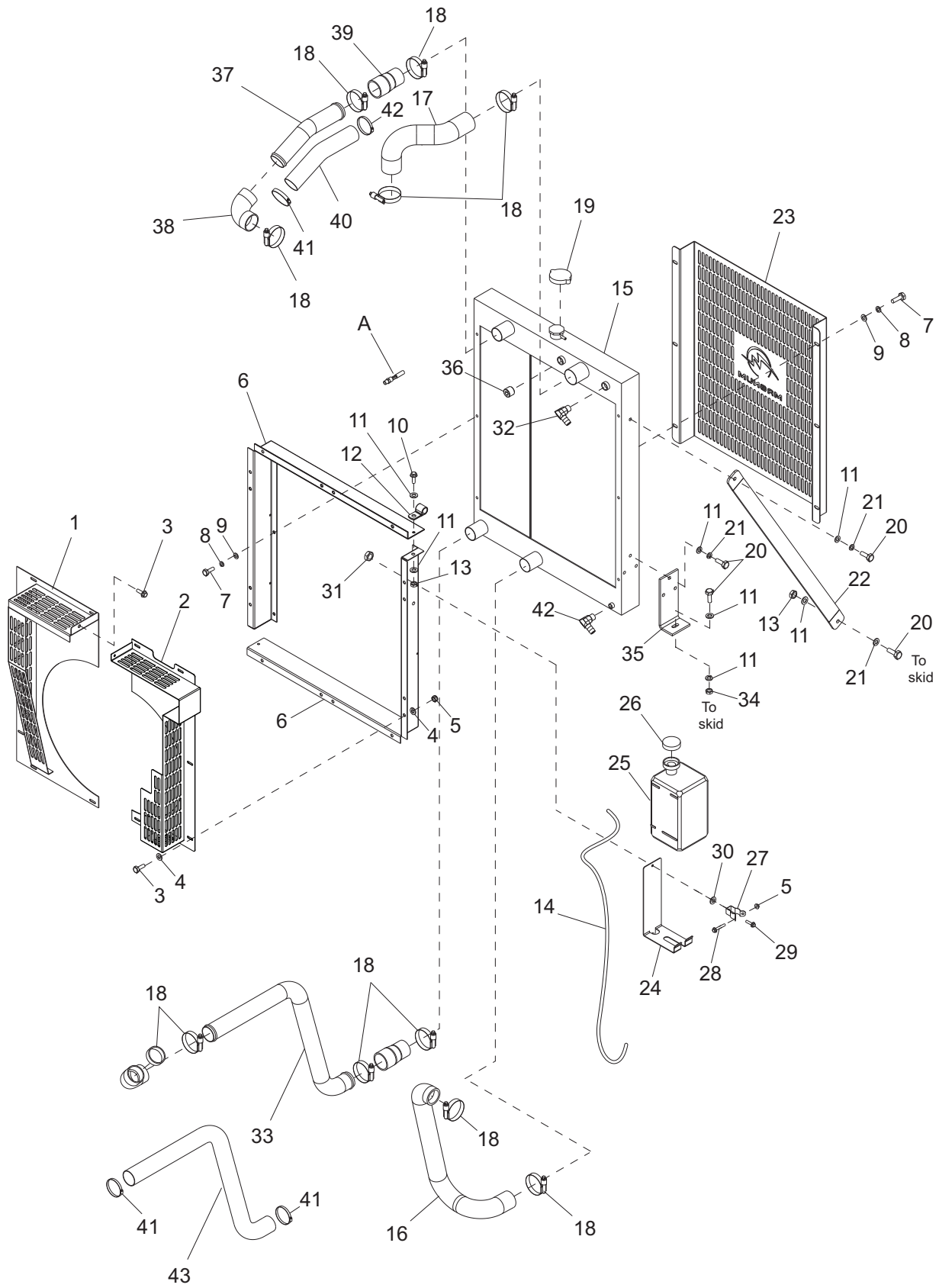

ITEM	PART NO.	QTY	DESCRIPTION	NOTES
1	49481B	1	Weldment, fan guard - lh	
2	49498B	1	Weldment, fan guard - rh	
3	60393	13	Screw, hx hd	
4	60243	28	Washer, flat .250	
5	60144	13	Nut, .250-20 nylock	
6	49473B	2	Radiator shroud	
7	60028	12	Screw, hx hd	
8	60271	12	Washer, split lock .312	
9	60119	12	Washer, flat .312	
10	60352	2	Screw, hx hd	
11	60386	20	Washer, flat .375	
12	16143	1	Clamp, tubing - .500	
13	60358	2	Nut, .375-16 hx nylock	
14	50018	3.5 ft	Hose, fuel .312 ID 50 psi	
15	49430	1	Radiator	
16	49433	1	Hose, lower radiator	
17	41045	1	Hose, upper radiator	
18	60660	12	Clamp, hose - constant trq	
19	19219	1	Cap - radiatorpressure small - 14 psi	
20	60205	12	Screw, hx hd	
21	60206	8	Washer, split lock .375	
22	49490B	2	Strut, radiator support	
23	49484R	1	Guard, rock	
24	41206B	1	Bracket, overflow jug	
25	41958	1	Jug, overflow 3.5 qt	
26	19714	1	Cap, overflow jug	
27	19726	1	Clamp, overflow jug	
28	60414	1	Screw, hx hd	
29	60062	2	Screw, pan hd phil	
30	60237	2	Washer, flat SAE #10	
31	60061	2	Nut, 10-32 hx nylock	
32	61014	1	Fitting, 90-.500 mnpt x .625 barb brs	
33	49432BH	1	Pipe, CAC out	
34	60140	2	Nut, .375-16 hex	
35	49475B	2	Bracket, radiator mounting	
36	18394	1	Fitting, plug - .500NPT x internal hex	
37	49471BH	1	Pipe, CAC in	
38	27775	2	Hose, CAC - 2.00 x 90 deg	
39	27993	2	Hose, CAC - 1.75-2.00 x 4.00	
40	26478	1.5 ft	Sleeve, high temp - 2.00	
41	60660	4	Clamp, hose - const. torque	1.75-2.6.25
42	63176	1	Fitting, radiator drain	
43	26478	3 ft	Sleeve, high temp - 2.00	
A	65592	1	Sensor, low coolant	Option

CONTROL BOX ASSEMBLY

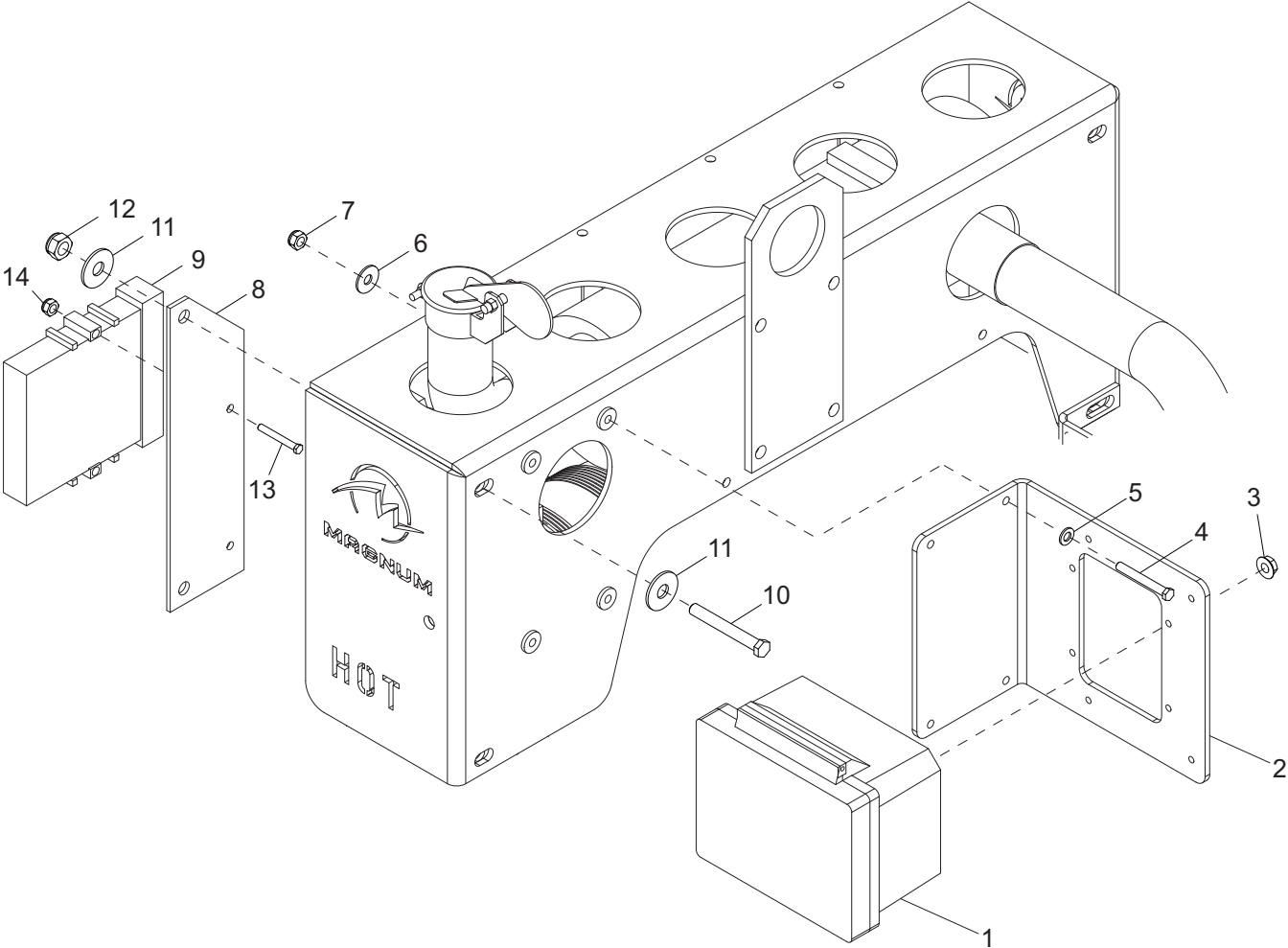

ITEM	PART NO.	QTY	DESCRIPTION	NOTES
1	49501	1	Control box assy - w/controller	
2	49494B	1	Bracket, control box mounting	
3	-	4	Nut	Included with P/N 49501
4	62001	4	Screw, .312-18 x 1.250 std hex	
5	60119	4	Washer, .312 flat .875/.070	
6	60729	4	Washer, .375 fndr 1.500/.090	
7	60303	4	Nut, .312-18 nylock	
8	49530B	1	Bracket, ECU mounting	
9	-	1	ECU	
10	50215	2	Screw, .500-13 x 4.00 std hex	
11	60309	4	Washer, .500 flat 1.060/.090	
12	60307	2	Nut, .500-13 nyk	
13	60403	2	Screw, .312-18 x 2.000 std hex	
14	60303	2	Nut, .312-18 nyk	

WET PRIME PUMP ASSEMBLY

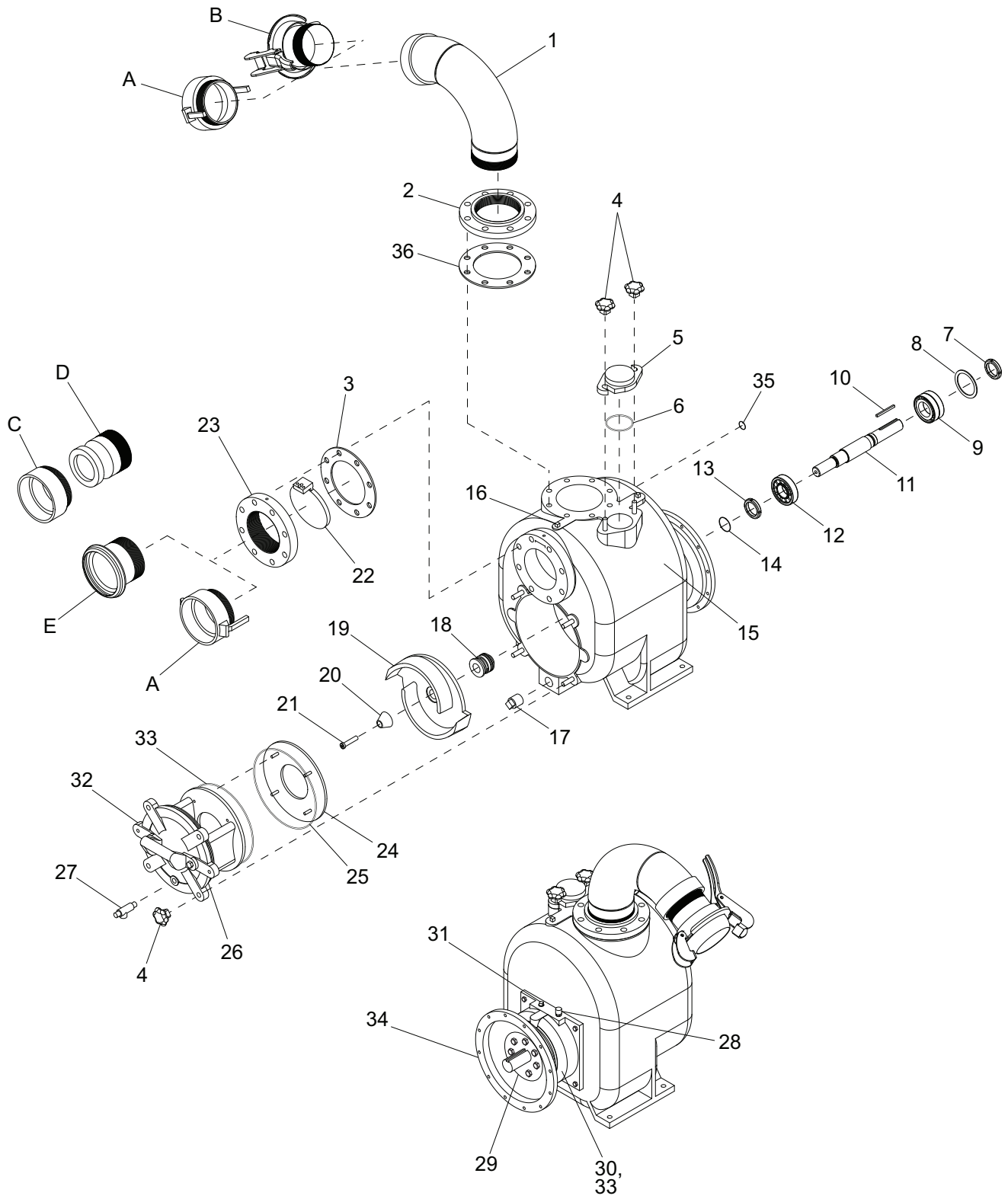

ITEM	PART NO.	QTY	DESCRIPTION	NOTES
1	41317B	1	Weldment, pump outlet tube	
2	41306B	1	Outlet NPT flange 6"	
3	43680	1	Gasket - suction valve	
4	41208B	6	Hand knob	
5	41209B	1	Prime fill cover	
6	41210	1	Prime fill cover gasket 4"/6"	
7	41872	1	Outboard oil seal 4"/6"	
8	41873	1	Snap ring 4"/6"	
9	30860	1	Bearing	
10	41579	1	Key, shaft	
11	43667	1	Shaft	
12	43665	1	Bearing	
13	41872	1	Inboard oil seal 4"/6"	
14	41892	1	Bearing housing O-ring 6"	
15	43676	1	Volute	
16	41893	1	Check valve pin 6"	
17	60988	1	Plug, 1.00 NPT square drv	
18	41219	1	Seal assembly	
19	41220	1	Impeller 6"	
20	41883	1	Impeller washer 4"/6"	
21	41882	1	Impeller screw 4"/6"	
22	41218	1	Check valve 6"	
23	41225B	1	Inlet NPT flange 6"	
24	41221	1	Wear plate 6"	
25	43681	1	O-ring inspect cover	
26	43682	1	Cover inspect	
27	41216	1	Relief valve	
28	41871	1	Bearing housing vent 4"/6"	
29	43668	1	Bearing cap	
30	43679	1	Bearing housing	
31	41870	1	Seal vent plug 4"/6"	
32	43674	1	Handle-cover	
33	49289	2	Inspection cover o-ring viton 6.00	
34	30862	1	Bracket, SAE 4	
35	30859	1	Seal flush o-ring	
36	41061	1	Gasket, pump flange - 6"	
--	49500	1	Sight glass - .75NPT	Not shown
--	43677	1	Plate seal	Not shown
--	43670	1	Basket bearing cap	Not shown
--	43675	-	Shim kit - impeller	Not shown
--	49851	1	Seal seat gasket - ES6	Not shown
--	41889	1	Seal sleeve O-ring 4"/6"	Not shown
A	41328	2	Cam & groove coupler	Optional
B	41324	1	Ball and lock ring	Optional
C	41584B	1	Weldment, pump fitting 45°	Optional
D	41586	1	Cam and groove	Optional
E	41326	1	Socket -male galv.	Optional

TRAILER ASSEMBLY

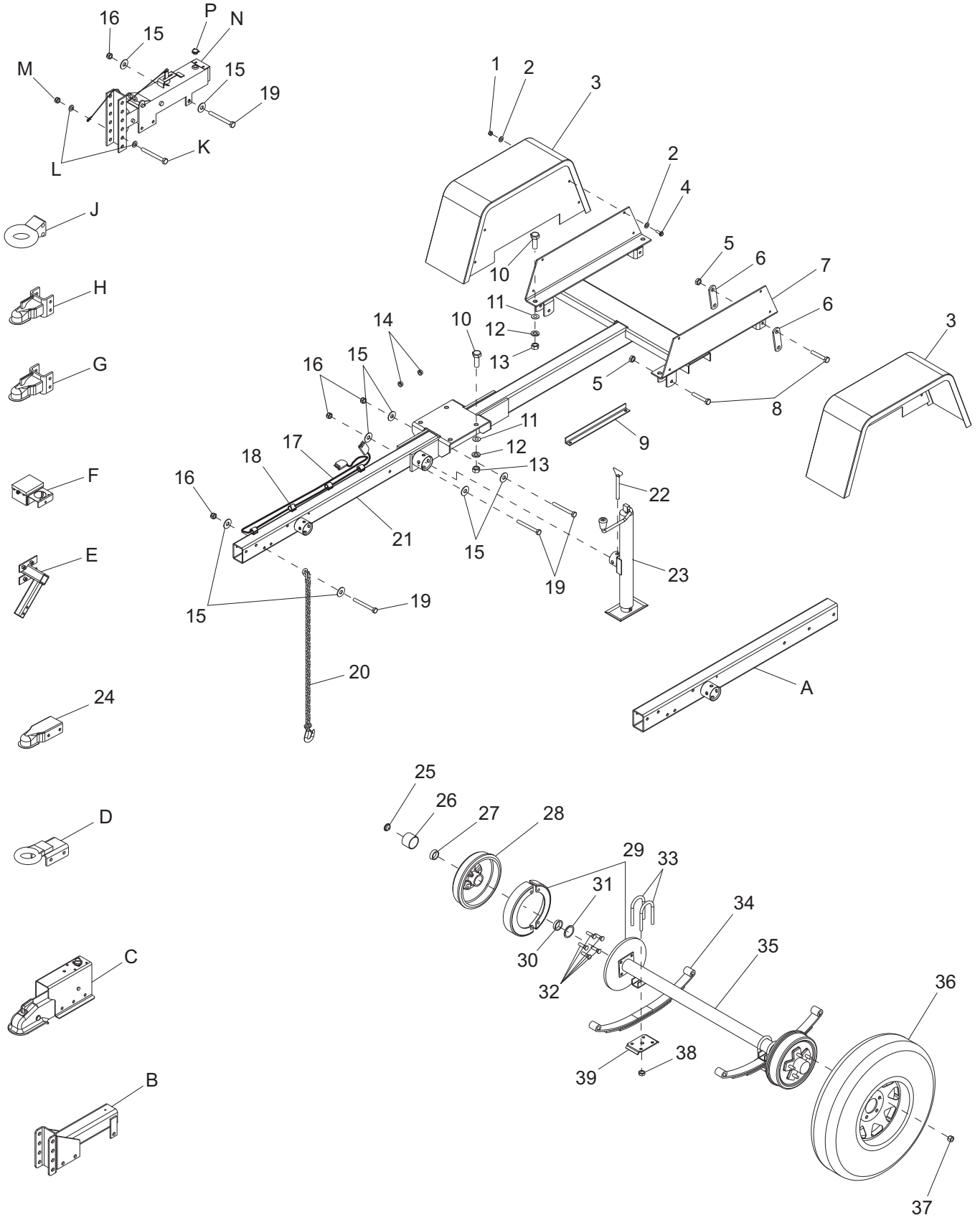

ITEM	PART NO.	QTY	DESCRIPTION	NOTES
1	60140	8	Nut, .375-16 hx hd	
2	60386	16	Washer, flat .375	
3	22743B	2	Fender, single wheel	
4	60179	8	Screw .375-16X.750 hx hd	
5	60504	6	Nut, hx shackle lock	
6	19637	4	Plate, shackle bracket	
7	24811B	1	Weldment, trailer chassis	
8	60503	6	Screw, .562-18 hx shackle	
9	24691B	1	Brace, tongue shipping	
10	60383	6	Screw, hx hd	
11	60247	6	Washer, flat .750	
12	60248	6	Washer, split lock .750	
13	15293	6	Nut, .750-10 hx	
14	22340	2	Bushing, 1.00 OD X .75 ID	
15	60309	14	Washer, flat .500	
16	60307	7	Nut, .500-13 hx nylock	
17	23205	1	Harness, trailer	
18	61010	7	Clamp, tubing - heavy duty	
19	60659	7	Screw, hx hd	
20	23367	2	Chain, safety	
21	24812B	1	Weldment, flip tongue	
22	23256	1	Pin, jack - tube mounted	
23	13051	1	Jack assy, top wind	
24	15103	1	Coupler, 2" ball/3" channel	
25	11254	2	Plug, grease cap - for zerk	
26	23170	2	Cap, grease - w/ rubber plug	
27	24831	2	Roller bearing - outer	
28	26452	2	Brake drum - 12" 6 on 5.5"	
29	26572	2	Surge brake assy, RH	
	26571	2	Surge brake assy, LH	
	26574	2	Electric brake assy, RH	Option: electric brake
	26573	2	Electric brake assy, LH	Option: electric brake
30	24830	2	Roller bearing - inner	
31	24832	2	Bearing seal axle	
32	60963	12	Stud, wheel - axle	
33	40875	4	U-bolt	
34	23912	2	Spring, 5000# axle	
35	22877	1	Axle, 5000#, hydraulic	
	22876	1	Axle, 5000#, electric	Option: electric brake
36	18377	2	Wheel, ST225/75R15	
37	60096	12	Nut, .500-20 wheel lug	
38	26441	8	U-bolt nut, 1/2-20 plated	
39	40874	2	Tie plate	
A	24824B	1	Weldment, flip tongue	Option: adj. actuator/elec brakes
B	19379B	1	Weldment, hitch elec.	Option: electric brake
C	24304	1	Actuator, hyd srg brk - 2"ball	Option: 2" ball
D	11032	1	Weldment, lunette ring - 3"	Option: 3" ring
E	12235B	1	Weldment, spare tire holder	Option: spare tire holder
F	19417	1	Breakaway Kit	Option: breakaway kit
G	19518	1	Coupler, 2" ball for adj hitch	Option: 2" ball adjustable hitch
H	19519	1	Coupler, 2.31 ball	Option: 2.31" ball
J	19335B	1	Coupler, lunette ring - 3" adj	Option: 3" ring adjustable hitch
K	60239	2	Screw, hx hd	Option: adjustable hitch
L	60180	4	Washer, flat .625	Option: adjustable hitch
M	60240	2	Nut, .625-11 hx nylock	Option: adjustable hitch
N	40529	1	Actuator, hyd srg brk - adj	Option: adjustable hitch
P	30248	1	Cap, actuator, sealed	Option: adjustable hitch

TRAILER BRAKE LINES

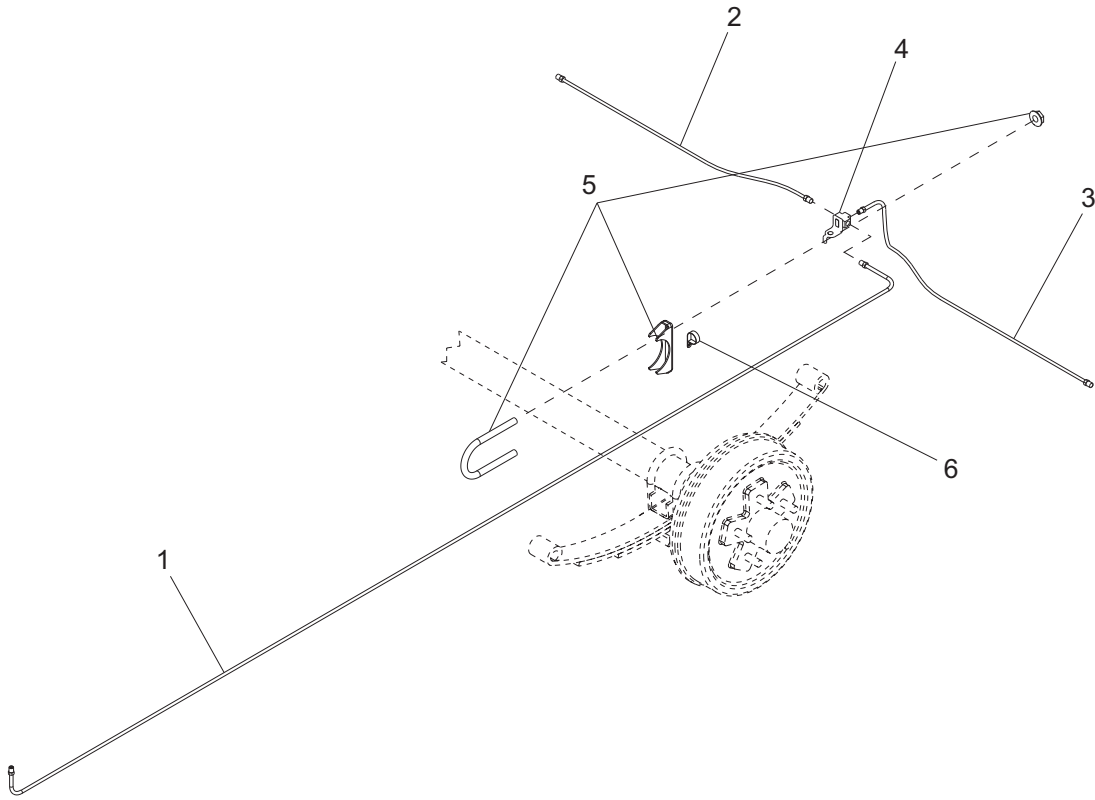

ITEM	PART NO.	QTY	DESCRIPTION	NOTES
1	24688	1	Hose, brake - male/male	
2	40495	1	Line, brake - .188 x 20.00	
3	40494	1	Line, brake - .188 X 30.00	
4	19252	1	Fitting, brake line T w/brckt	
5	61028	1	Clamp, muffler - 2.50 lt duty	U-bolt & saddle
6	61010	1	Clamp, tubing - heavy duty	

REV: A
PART NO: 49520
02.17.12